

MODEL	TORQUE		INERTIA	BENDING MOMENT		HEAT DISSIPATION	WEIGHT	
MTL 0.13-XXX	.11 - 2 in oz	.001 - .014 Nm	3.5×10^{-5} in-oz sec ²	2 lb-in	.22 Nm	2.2 WATTS	.16 lbs	.071 kg

REVISIONS			
REV.	ECN.	DESCRIPTION	DATE

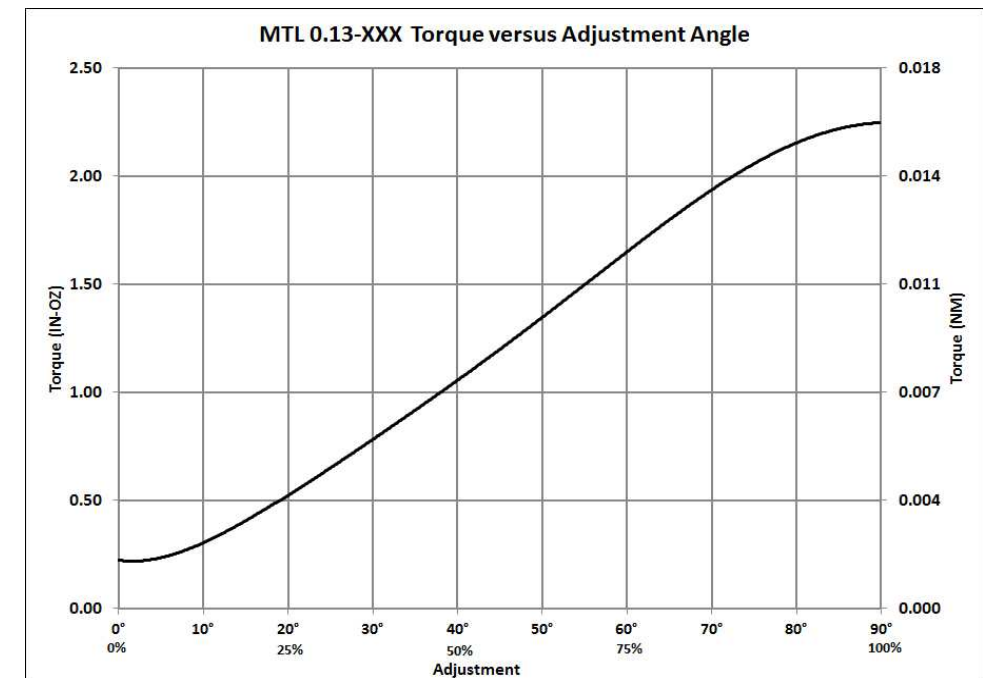
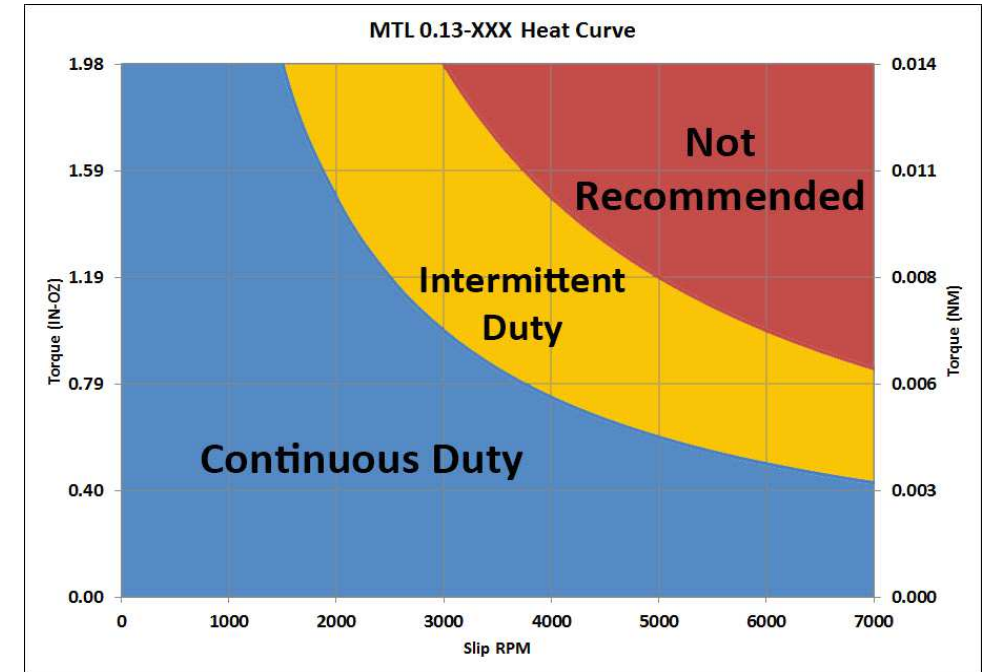
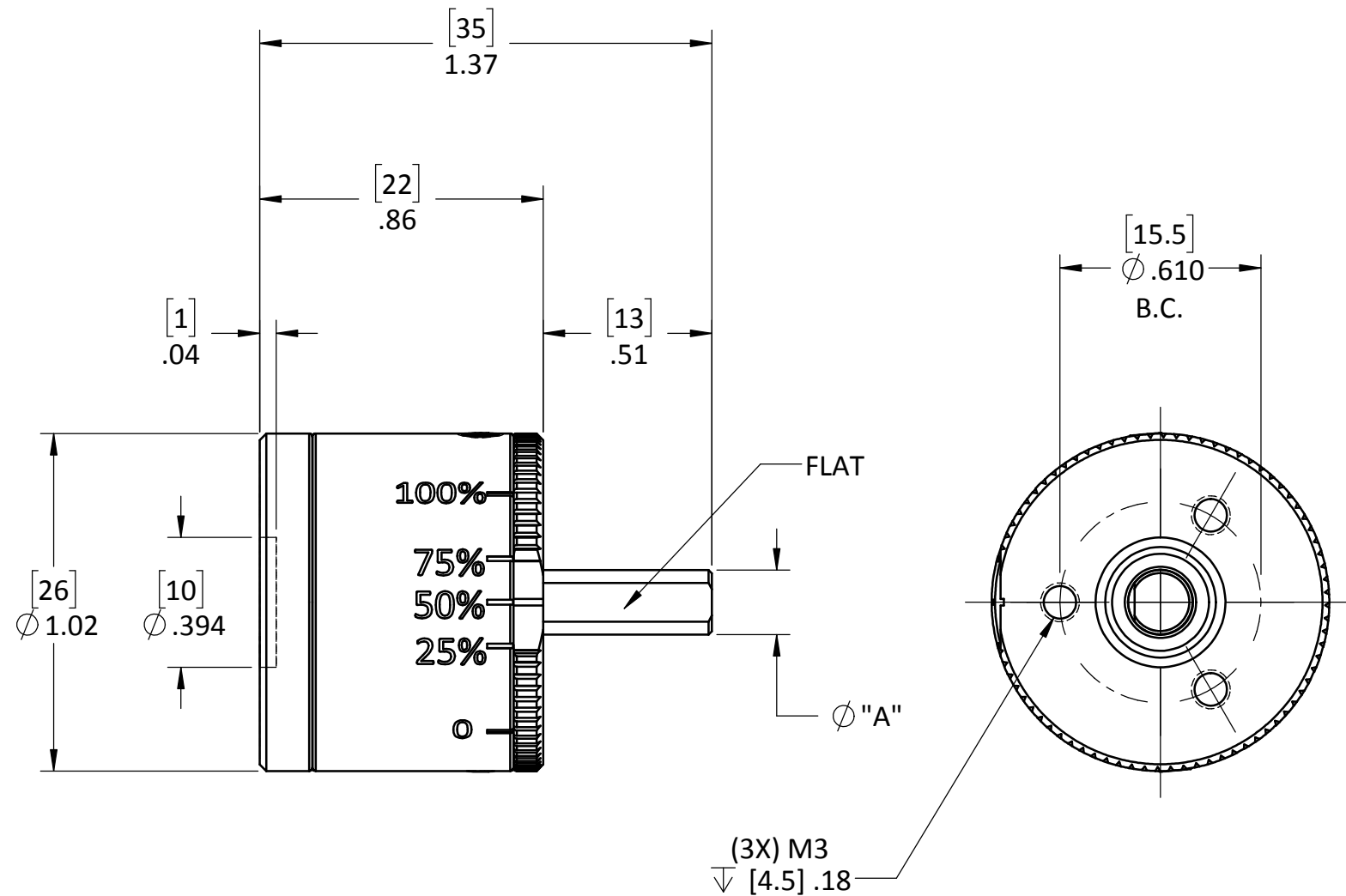

MODEL	"A" DIMENSION	
MTL 0.13 - 3/16	.187 ^{-0.001}	4.75 ^{-0.03} mm
MTL 0.13 - 5	.197 ^{-0.001}	5.00 ^{-0.03} mm

USED ON MTL 0.13	SCALE 2:1	MATERIAL SEE PRT DWG	 43 TOWN FOREST ROAD OXFORD, MA 01540
UNLESS OTHERWISE SPECIFIED:		FINISH SEE PRT DWG	
ALL DIMENSIONS ARE IN INCHES TOLERANCES: DECIMAL: .XX ± .01 .XXX ± .005 ANGULAR: ± 1° GEN. CONCENTRICITY: .001 T.I.R. MACH. FILLETS: .010 R MACH. EDGES: .015 R OR CHMF. UNSPECIFIED RADII: .015 R IN MICROINCHES RMS 32 GEOMETRIC: TO MIL-ST'D. 8 REMOVE ALL BURRS & SHARP EDGES			DRAWN R. A. 10/14/15 CHECKED DESCRIPTION CUT SHEET DWG. NO. _____ REV. _____ MTL 0.13-XXX
SIZE: B			

THIS DRAWING IS THE PROPERTY OF MAGNETIC TECHNOLOGIES LTD. AND IS SUPPLIED ON THE EXPRESS CONDITION THAT IT SHALL NOT BE LENT, COPIED, REPRODUCED NO DISCLOSED TO ANY OTHER PERSON, IN WHOLE OR IN PART WITHOUT THE WRITTEN CONSENT OF MAGNETIC TECHNOLOGIES LTD.